



**Comhairle Contae
Loch Garman
Wexford
County Council**

Wexford County Council Public Lighting Specification

December 2017

Prepared By:
Recommended By:
Approved by:

*Redmond Analytical Management Services Ltd.
Enda Waters, A\ Executive Engineer
Diarmuid Houston, Senior Planner*



Contents

| | |
|--|----|
| Table of Figures..... | ii |
| Introduction..... | 1 |
| Objectives..... | 1 |
| 1 General Requirements..... | 1 |
| 2 Safety and Health..... | 2 |
| 3 Client and Designer Duties..... | 3 |
| 4 Works to Partial Circuits..... | 3 |
| 5 Lighting Design..... | 4 |
| 6 Design Approval..... | 5 |
| 7 Electrical Connection..... | 7 |
| Conclusion..... | 7 |
| References..... | 8 |
| Appendix A Cable and Ducting Specification..... | 9 |
| Appendix B Cable Access Chamber Specification..... | 11 |
| Appendix C Column and Bracket Specification..... | 12 |
| Appendix D Supply Cabinet Specification..... | 15 |
| Appendix E Column Installation..... | 18 |
| Appendix F Electrical Design..... | 21 |
| Appendix G LED Luminaire Specification..... | 23 |
| Appendix H Taking in Charge..... | 27 |
| Addendum 1 Designer Checklist..... | 28 |
| Addendum 2 Column Details..... | 29 |
| Addendum 3 Duct Details..... | 30 |



Table of Figures

| | |
|--|----|
| Figure 1: Road crossing duct detail | 9 |
| Figure 2: Duct under grass or pavements. | 9 |
| Figure 3: Typical cable access chamber..... | 11 |
| Figure 4: Cable slot detail. | 12 |
| Figure 5: Pillar spacing | 15 |
| Figure 6: Midi pillar electrical schematic. | 16 |
| Figure 7: Door positioning. | 18 |
| Figure 8: Column door height..... | 19 |
| Figure 9: Column Electrical Schematic..... | 20 |

*Wexford County Council would like to thank
Redmond Analytical Management Services Ltd.
for their technical assistance in preparing this specification.*



Introduction

Wexford County Council intend to ensure that all developments with a public lighting element will provide a sustainable, energy efficient lighting solution. This document refers to international and national standards, along with codes of practise and best practise documents that designers must comply with in order to meet our required standards.

Whilst this document does not intend to specify particular lighting equipment, it does intend to stipulate a minimum performance standard for all the equipment utilised within public lighting installations.

In addition, this document does not specify a specific lighting category with which designers should comply, rather designers should select appropriate lighting levels from the pertinent standard with which to light their projects and confirm this selection with Wexford County Council prior to undertaking the design. This is to enable the competent lighting designer scope to produce appropriate, compliant, and energy efficient lighting solutions.

Objectives

Public lighting is an important addition to the built environment. Lighting gives a sense of safety and security to our residential areas and vibrancy to our commercial centres. Lighting makes navigating about our community easier through the hours of darkness, improves traffic flow and raises general safety.

Public lighting infrastructure in the county places a considerable burden on the local authority's resources and therefore it is in everyone's interests that this infrastructure is as energy efficient and maintenance friendly as possible.

Wexford County Council's *Public Lighting Specification* lays down how the lighting task should be approached for all applications except motorway, primary and secondary traffic routes; which are dealt with separately; regardless of whether the lighting is to be taken in charge or not.

This public lighting specification supersedes all previous public lighting specifications published by Wexford County Council. The guidance offered for public lighting layouts within *Recommendations for Site Development Works for Housing Areas* is no longer acceptable.

1 General Requirements

Wexford County Council situated at County Hall, Carricklawn, Wexford, is the official lighting authority for housing estates, industrial and commercial developments in county Wexford.

All lighting schemes in housing, industrial or commercial developments carried out by developers or their contractors in county Wexford shall comply with the requirements of, and be approved by, Wexford County Council, irrespective of whether the lighting is to be taken in charge or not.

This specification sets down appropriate standards and technical specifications which shall be complied with by developers undertaking public or private developments to



assist them in providing adequate lighting to the Irish Standard for public lighting *I.S. EN 13201-2:2015* (National Standards Authority of Ireland, 2016) while observing *ETCI* regulations and *ESB Networks* distribution system interface requirements. This document sets out the general public lighting requirements for all such developments.

In addition, designers should observe the general guidance offered in *BS 5489-1:2013 Code of Practice for the Design of Road Lighting Part 1: Lighting of Roads and Public Amenity Areas* (British Standards Institute, 2012). Particularly with regard to locating columns, and the calculation of maintenance factors.

Where special circumstances occur, that require deviation from this document, these shall be clearly agreed in writing with the Roads Department of Wexford County Council in advance of any work commencing on site and as such, must be adhered to for any public lighting installation to be taken in charge by the Roads Department of Wexford County Council.

LED luminaires shall only be considered for public lighting applications.

Specifications and requirements for the various individual components that make up a general lighting infrastructure is laid out in *appendages A through H*. Any detail of an individual lighting design not covered should be brought to the attention of Wexford County Council for clarification.

2 Safety and Health

- 2.1 The developer shall comply with all the duties laid down in the *Safety, Health and Welfare at Work (General Applications) Regulations 2007* (Department of Enterprise, Trade and Employment, 2007).
- 2.2 The developer shall comply with all the duties laid down in the *Safety, Health and Welfare at Work (Construction) Regulations 2013* (Department of Jobs, Enterprise and Innovation, 2013)
- 2.3 All persons employed on the installation of public lighting must have received appropriate safety and health training in accordance with the *Safety, Health and Welfare at Work Act 2007* (Department of Enterprise, Trade and Employment, 2007) and *The Safety Health and Welfare at Work (Construction) Regulations 2013* (Department of Jobs, Enterprise and Innovation, 2013) and training in roadside working in accordance in particular with Part 13 of the *Safety, Health & Welfare at Work (Construction) Regulations 2013* (Department of Jobs, Enterprise and Innovation, 2013) as amended and the *ESB Networks Code of Practice for avoiding Danger from Overhead Electricity Lines* (ESB Networks, 2008).
- 2.4 Any person who carries out specific works on public lighting in proximity to ESB networks is to hold an appropriate public lighting *Safety Approval Certificate* confirming that he is trained and competent to carry out such works.
- 2.5 Account shall be taken of any traffic management measures that may be required during the installation of public lighting schemes. This includes the requirement that a traffic management plan be designed by a holder of a current valid *Traffic Management Designer CSCS card* and implemented on site by a current valid *CSCS Signing, Lighting and Guarding* on roads license holder.



3 Client and Designer Duties

- 3.1 Developers and/or their agents shall ensure they comply with their statutory duties defined in the *Safety, Health and Welfare at Work (Construction) Regulations 2013*, particularly those duties detailed in *Part 2, Section 7 (2) and (5)* (Department of Jobs, Enterprise and Innovation, 2013).
- 3.2 Designers submitting lighting designs shall ensure they comply with their statutory duties defined in the *Safety, Health and Welfare at Work (Construction) Regulations 2013*, particularly those duties detailed in *Part 2, Section 15* (Department of Jobs, Enterprise and Innovation, 2013).
- 3.3 The *Safety, Health and Welfare at Work (Construction) Regulations 2013* clearly states that the *client (developer)* must appoint a '*competent designer*' to undertake all design work. This statutory duty applies to lighting and associated electrical infrastructure design. The appointed *competent designer* must comply with their statutory duties which are clearly defined in *S.I. 291*.
- 3.4 Designers must prepare, record and store written documentation clearly showing how design decisions are arrived at. Under *S.I. 291* the designer must share (if requested) such records with others that have an interest in the project. Wexford County Council clearly has an interest in all designs carried out for installation in its locale and may request such records from designers.
- 3.5 Wexford County Council reserve the right to have lighting designers demonstrate their competence to undertake lighting and associated electrical infrastructure designs.
- 3.6 Developers and their agents should be aware that 'designs' offered on an 'advisory basis' or on a *pro bono* basis still have to comply with the statutory duties defined in the *Safety, Health and Welfare at Work (Construction) Regulations 2013* (Department of Jobs, Enterprise and Innovation, 2013).

4 Works to Partial Circuits

- 4.1 All works to partial circuits will be subject to the full testing and certifying requirements of the *National Rules for Electrical Installations* (Electro-Technical Council of Ireland, 2016).

Attention shall be given to the requirements of *Annex 63B paragraph 1*. "Should the installer become aware of any defect in any part of the installation that would impair the safety of the new work, the client must be informed in writing thereof. No new work should commence until these defects have been made good." (Electro-Technical Council of Ireland, 2016)
- 4.2 All electrical installation work is to be carried out by a contractor registered with *RECI* or *ECSSA*.
- 4.3 Where existing hardware (columns, supply cabinets, etc.) are to be relocated/reused or in any way retained, the contractor must certify that all retained hardware is structurally sound and without damage to the protective coatings.
- 4.4 All due care must be taken in the protection of existing hardware. Any damage to existing equipment (both electrical and structural) must be reported to the local



authority and it is the contractor's responsibility to supply and replace any damaged equipment in the course of their works.

- 4.5 Prior to the disconnection of any existing public lighting installations, a full *Risk Assessment* shall be undertaken regarding the impact of the interruption of the street lighting provision on all users - pedestrian, cyclist and vehicular. If deemed necessary, temporary lighting shall be provided.
- 4.6 Where the interruption of the street lighting provision cannot be avoided by the phased scheduling of works, written agreement must be sought from Wexford County Council for permission to temporarily power down and re-energise sections of the circuits on a phased basis.
- 4.7 If granted, the permission referenced above in no way absolves the contractor from his previously stated responsibilities regarding the inspection and testing of the renewed circuits.
- 4.8 All waste is to be disposed of in accordance with the *WEEE Directive*.

5 Lighting Design

- 5.1 Lighting designers shall refer to Wexford County Council's *Public Lighting Specifications* and ensure they comply fully with all requirements.
- 5.2 Lighting designs shall comply with Wexford County Council's *Public Lighting Specifications* even if there is no intention for the lighting infrastructure to be taken in charge by Wexford County Council.
- 5.3 Lighting designers should liaise with the Roads Department of Wexford County Council at an early stage of the design process, to confirm the appropriate lighting classification.
- 5.4 Lighting designers shall refer to the following Regulations, Standards, and Guidance Documents:

S.I No. 291 of 2013: Safety, Health and Welfare at Work (Construction) Regulations 2013.

National Rules for Electrical Installations ET 101: 2008 Fourth Edition or later.

I.S. EN 13201-2:2015 Road Lighting – Part 2: Performance Requirements.

BS 5489-1:2013 Code of Practice for the Design of Road Lighting. Part 1: Lighting of Roads and Public Amenity Areas.

Housing Schemes: Guidebook for ESB Networks Standards for Electrical Services (Revision 5).

Relevant guidance documents available from the *Institution of Lighting Professionals* as appropriate.

Relevant guidance documents available from the *Society of Light and Lighting* as appropriate.



- 5.5 Lighting designers shall approach the design process in a holistic manner, taking account of lighting levels in the general area and at the access points to the project/development. Maintenance access and longevity of installation shall be central to the design.
- 5.6 Lighting designers shall pay attention to the *General Principles of Prevention* (Department of Jobs, Enterprise and Innovation, 2013) both for construction and for future maintenance.
- 5.7 Careful consideration shall be given to future maintenance requirements. In particular with regard to safe access for maintenance crews to the lighting equipment, including safe ingress and egress to the equipment location.
- 5.8 The design should represent the planned construction phases and should be self-contained within each construction phase.
- 5.9 No component of the lighting infrastructure shall pass through, or under, private property.
- 5.10 Consideration shall be given to the protection of columns from vehicle strikes. Column set back guidance offered in 4.3.3.3 of *BS5489-1:2013* (British Standards Institute, 2012) shall be observed.

When shared surfaces are used, such as in *Homezones* a suitable method of column protection shall be offered that does not conflict with the ethos of shared surface design principles. A written risk assessment shall be undertaken to support column locations and the assessment provided to the Roads Department of Wexford County Council for approval prior to installation work commencing.

- 5.11 The effects of planned and existing trees and tall shrubs shall be considered during the design process to ensure that they do not block light and cause excessive shadowing. A minimum clearance equal to the column height shall be used to ensure light distribution is not inhibited.

6 Design Approval

- 6.1 All lighting, lighting infrastructure and electrical designs must be approved in writing to the Roads Department of Wexford County Council before any associated works commence on site.
- 6.2 The design approval system is a simple pass or fail process and is designed to encourage sustainable, energy efficient lighting solutions, utilising appropriate modern equipment and technology.
- 6.3 Wexford County Council provides a check list for designers to complete and submit with their design for approval, shown in *Addendum 1*. The list should be completed along with the required supporting documents. Incomplete submissions will not be approved.
- 6.4 All exterior lighting and associated electrical infrastructure must be submitted in the following format:

6.4.1 Lighting Reality® calculations in soft format. The cover shall show:

- The identity of the lighting designer.



- The project name.
- The lighting classification designed to.
- The combined maintenance factor for the luminaire and how it was derived.
- The ambient temperature of the photometry used.

6.4.2 Lighting Reality® report in PDF format.

6.4.3 CAD drawing in soft format showing the following information:

- The site boundary.
- All landscaping details.
- All services.
- All private areas to be hatched and identified.
- Individually numbered columns with icons of a size to allow accurate assessment of the column positions.
- PL ducting layout.
- PL cable access chambers.
- Individually numbered public lighting midi pillar locations.
- ESB cabinet locations.
- Individually numbered single line circuit diagrams.
- All duct, column foundation or any other detail shall only show Wexford County Council approved versions. Non approved versions shall not be included in any drawing submitted to contractors.

6.4.4 Technical specifications for the proposed equipment, including *TM21* and *LM80* reports.

6.4.5 Written details outlining the OEM warranty and the procedure for transferring warranty to Wexford County Council when the development is presented for taken in charge.

6.4.6 Voltage drop calculations for each circuit.

6.4.7 Energy consumption calculations reflecting any designed dimming regime.

6.5 The substitution of *PDF* type files over requested soft copy versions prevent Wexford County Council from fulfilling their statutory duties detailed in *S.I. 291* and are therefore not acceptable.

6.6 Any revisions or alterations to the approved lighting design must be submitted to the Roads Department of Wexford County Council for approval before being undertaken on site.



7 Electrical Connection

- 7.1 Electrical loads for public lighting shall be designed so that a single phase supply is sufficient and must not exceed 2kVA per connection point, so as to allow an unmetered connection to the electrical distribution network.
- 7.2 In all cases, the developer is responsible for arranging and carrying out the connection to the electrical distribution system.
- 7.3 It is the developer's responsibility to ensure the installation meets all electrical safety requirements and is certified by competent persons.
- 7.4 The developer must maintain the installation and pay all electrical bills until taken in charge.
- 7.5 The developer will be liable for all costs associated in making good any faults found during the pre-taking in charge inspection.

Conclusion

Wexford County Council believes that adhering to the standards and specifications identified in this document will result in a sustainable and energy efficient lighting infrastructure that brings value and security to residents and the general public using amenities in the county.

The energy efficiency measures stipulated will greatly assist in meeting the European Communities' energy efficiency targets for 2020 and the planned targets for 2030, as well as meeting the statutory requirements defined in the *European Union (Energy Efficiency) Regulations 2014* (Department of Communications, Energy and Natural Resources, 2014).

Please contact us if there is any aspect of Wexford County Council's public lighting strategy that requires clarification.



References

British Standards Institute, 2010. BS 7654:2010. Specification for single-phase street lighting cut-out assemblies for low-voltage public electricity distribution systems. 25 A rating for highway power supplies and street furniture. London: British Standards Institute.

British Standards Institute, 2013. BS EN 60529:1992+A2:2013. Degrees of protection provided by enclosures (IP code). London: British Standards Institute.

British Standards Institute, 2002. BS EN 62262:2002. Degrees of protection provided by enclosures for electrical equipment against external mechanical impacts (IK code). London: British Standards Institute.

British Standards Institute, 2010. BS 7657:2010. Specification for cut-out assemblies up to 100 A rating, for power supply to buildings. London: British Standards Institute.

British Standards Institute, 2012. BS 5489-1:2013. Code of practice for the design of road lighting Part 1: Lighting of roads and public amenity areas. Seventh ed. London: s.n.

British Standards Institute, 2013. BS EN 40-3-1:2013. Lighting columns. Design and verification. Specification for characteristic loads. London: British Standards Institute .

British Standards Institute, 2013. Low-voltage fuses. Supplementary requirements for fuses for use by authorised persons (fuses mainly for industrial applications). Examples of standardised systems of fuses A to K BS HD 60269-2:2013, BS 88-2:2013. London: British Standards Institute.

Department of Communications, Energy and Natural Resources, 2014. The European Union (Energy Efficiency) Regulations 2014 S.I. No 426 of 2014. Dublin: The Stationary Office.

Department of Enterprise, Trade and Employment, 2007. S.I. No 299 of 2007 Safety, Health and Welfare at Work (General Applications) Regulations 2007. Dublin: The Stationary Office.

Department of Jobs, Enterprise and Innovation, 2013. S.I. 291 Safety, Health and Welfare at Work (Construction) Regulations 2013. Dublin: The Stationary Office.

Electro-Technical Council of Ireland, 2016. National Rules for Electrical Installations. Fourth Edition. Dublin: Electro-Technical Council of Ireland.

ESB Networks, 2008. Code of Practise for Avoiding Danger from Overhead Electricity Lines. First ed. Dublin: s.n.

ESBN, 2008. National Code of Practise for Customer Interface. Fourth ed. Dublin: ESBN.

European Committee for Electro-technical Standardisation, 2009. BS EN 60598-1:2008. Luminaires. General requirements and tests. London: British Standards Institute.

International Organisation for Standardisation, 2015. EN 1461 2009. Hot dip galvanized coatings on fabricated iron and steel articles - Specifications and test methods. Dublin: National Standards Authority of Ireland.

National Standards Authority of Ireland, 2015. I.S. EN ISO 9001: 2015. Quality Management Systems - Requirements. Dublin: National Standards Authority of Ireland.

National Standards Authority of Ireland, 2016. I.S. EN 13201-2:2015. Dublin: s.n.



Appendix A Cable and Ducting Specification

- A.1 All cables are to be installed in ducting. Ducting shall not run through, or below private property.
- A.2 No jointing of cables will be accepted in any circumstances.
- A.3 Two core *NYCY* cable, or three core *SWA* must be used throughout the installation, size to be selected by appropriate calculations, but a minimum of 6mm² shall be used.

3 core 2.5mm² cable shall be used between the column and luminaire. This cable shall have a circular cross section to ensure adequate sealing of the luminaire.

- A.4 Ducts must be single walled, colour red, high density polyethylene (H.D.P.E.). The duct shall have a nominal 100mm diameter. For runs shorter than 1m, flexible duct of 50mm is acceptable.

The duct must have the words "Public Lighting" stamped at 1m intervals. The letters must be 9mm in height.

- A.5 Ducting shall be laid in fully coupled unbroken lengths and shall run directly between the column pots and/or midi pillar. Draw wires must be provided at all termination points.

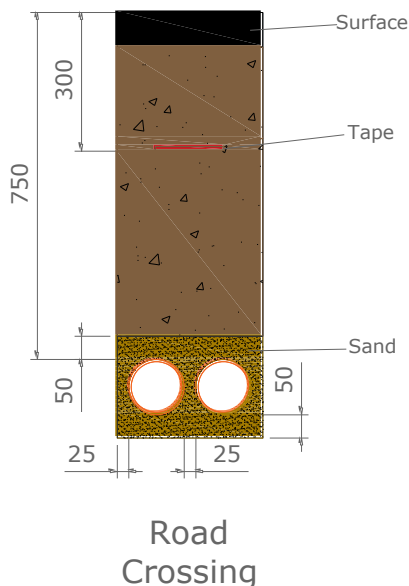

Figure 1: Road crossing duct detail

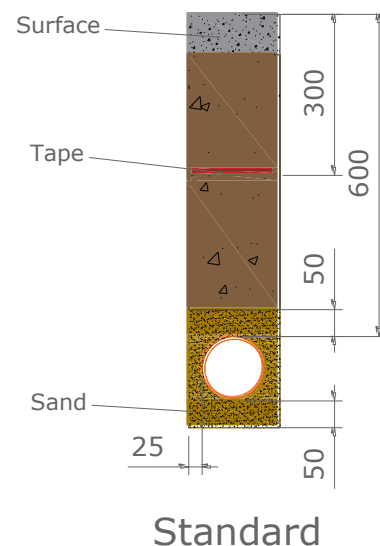

Figure 2: Duct under grass or pavements.



Ducting shall be laid to the appropriate depth as the *ETCI* requirements and surrounded by sand before burying with appropriate material as shown in *figures 1 and 2*.

All ducts shall be marked with electrical marking tape at 300mm below finished ground level.

Draw wires of at least 8kN must be provided at all termination points.

- A.6 Cable access chambers shall be provided where ducts take acute turns, or in any instance they cross beneath any surface used by vehicles, including any shared surfaces.
- A.7 At road crossings and under shared surfaces such as *Homezones*, spare ducting shall be provided. Ducting setback in relation to road edge will vary depending on the set back of rooted lighting columns.
- A.8 Ducting shall be properly coupled.



Appendix B Cable Access Chamber Specification

B.1 Access chambers must be provided at all access points for road crossings, acute bends in duct runs, duct junctions, and under shared surfaces and *Homezone* surfaces.

Access chambers shall only be installed in *Group 2* areas suitable for loading class D400 to be used at all trafficked locations.

Chambers shall be deep enough that ducts shall not rise or fall on their approach.

B.2 At road crossings and under shared surfaces spare ducting shall be provided. Ducting setback in relation to road edge will vary depending on the set back of rooted lighting columns. Spare ducts shall run between access chambers under road crossings and shared surfaces and *Homezone* surfaces.

B.3 Access chambers shall be 450mm square as a minimum. Larger sizes may be required when numerous public lighting supply cables pass through.

B.4 High strength engineering bricks or cast in situ concrete or standard concrete blocks shall be used to construct the manhole chambers directly under the cover and frame. Pre-fabricated chamber boxes shall not be used.

B.5 The chamber cover manufacturer shall be registered with and certified by either *NSAI*, *British Standards Institute of Quality Assurance Services* or *Lloyds Register Quality Assurance Register* for the design, manufacture, supply and verification of chamber covers under their quality assessment schedule to *ISO 9001* (National Standards Authority of Ireland, 2015).

B.6 The cover shall be lockable in place. There shall be provision for replacements of bolt and nut if damaged.

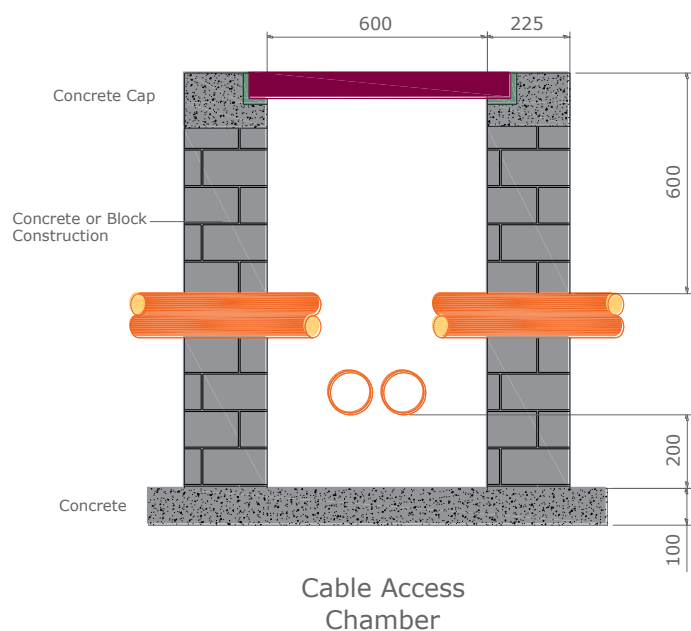

Figure 3: Typical cable access chamber



Appendix C Column and Bracket Specification

- C.1 All columns shall be of the same type within any one scheme. Tubular or octagonal steel columns which comply are acceptable and shall be protected against corrosion by hot-dip galvanising to *ISO EN 1461* (International Organisation for Standardisation, 2015).

Bespoke or decorative columns will only be permitted by prior agreement with the Roads Department of Wexford County Council.

- C.2 All lighting columns shall be designed to the *EN 40* and in accordance with *BD94/07* (British Standards Institute, 2013) for a minimum 25 year life for a *Terrain Category* of TC3 and reference the relevant 10 minute mean wind velocity.

Column specification and associated windage calculations must include for a 1.5m square sign and assume a 1.5m bracket length, even where the current design does not call for a sign or bracket.

- C.3 The lighting column manufacturer shall be registered with and certified by either *NSAI*, *British Standards Institute of Quality Assurance Services* or *Lloyds Register Quality Assurance Register* for the design, manufacture, supply and verification of road lighting columns and brackets under their quality assessment schedule to *ISO 9001* (National Standards Authority of Ireland, 2015).

The quality assurance certification shall relate to the specific lighting column material being proposed. Wexford County Council reserves the right to request proof of certification from the proposed column manufacturer.

- C.4 All octagonal columns must be fabricated with longitudinal welding only.

All tubular columns must incorporate an anti-rotational device.

- C.5 A vertical cable entry slot with smooth edges, rounded at top and bottom and measuring 150mm X 75mm shall be provided in the column root. The entry slot shall be in line with the column door opening. The top of the entry slot shall be at 300mm below ground level as shown in *figure 4*.

A bituminous coating to a level 250mm above finished ground level shall protect the planted portion and above of both the inside and outside of each column.

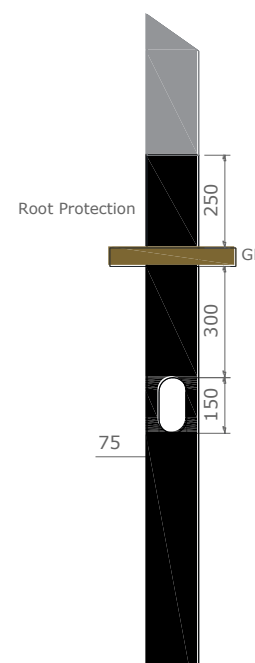

Figure 4: Cable slot detail.



- C.6 For octagonal columns, the door opening shall have a welded-in frame with an all-round weather strip. A flat steel door of minimum thickness 3mm secured by two triangular head bolts shall be fitted.

For all other columns, the door opening shall be plasma cut. Twin bolts shall be used. Receiving sockets shall be adjustable using non-corrosive materials to allow for interchangeable doors.

The locking triangular head bolts shall have a narrow neck under the head to take a retaining washer. The bolt threads shall be lightly greased to prevent seizing or binding. Bolts must be secured to an 8mm nut welded in place.

Nuts held by compression or clipped in place shall not be accepted.

- C.7 All doors shall be of a standard size and be fully interchangeable. They shall not require any site adjustment or modification to fit each column properly. They shall be a minimum of 385mm x 90mm.

- C.8 A baseboard, with a minimum working area equal to the door opening, shall be fitted in each column and shall be treated with intumescent varnish to prevent fire propagation.

The clearance between baseboard and inside face of door when secured shall not be less than 100mm. The baseboard must be capable of being removed and replaced. Baseboard fixings shall be recessed below the surface of the board so as not to impede the fixing of electrical equipment to the baseboard. An earth terminal shall be provided in a readily accessible position at the bottom of the opening.

- C.9 Columns located in areas inaccessible to standard maintenance equipment must be base-hinged columns as manufactured by Abacus Lighting or approved equivalent. Gear must be accessible by lowering the column only.

All base hinged columns must be delivered with a standard anti-vandal locking screw as standard.

The base hinged column must only be capable of being lowered with a universal lever.

- C.10 Where columns are to be installed into parks and green spaces and hinged columns are deemed inappropriate, vehicular access must be provided for maintenance actions. The minimum paved width required for the maintenance truck fitted with a hoist is 3.5m. The paved width shall be laid out in such a manner that the maintenance vehicle does not have to reverse to egress the area.

The paved path must have sufficient structural strength to support the weight of the truck and the pressure of the truck stabilisers without incurring damage.

- C.11 The use of outreach brackets on new installations is usually not necessary and should only be used where installation geometry is challenging. Columns shall be fitted with a spigot to suit the selected design luminaire.

Where outreach brackets are required for lighting performance reasons, both the columns and brackets assemblies shall conform to the deflection requirements of *Class 2* as defined in *IS EN 40-3-3* (British Standards Institute, 2013).



- C.12 The removable bracket arms for the columns shall be of steel construction and protected against corrosion by hot dip galvanising to *BS EN 1461* (International Organisation for Standardisation, 2015).

Bracket arms and column shaft shall be of the sleeve fitting type, with the bracket fitting snugly over the column.

- C.13 For tubular columns, the bracket shall be secured by eight hexagonal headed stainless steel bolts, minimum diameter 8mm. Brackets used for columns greater than 8 metres must have 8mm nuts welded to the outer face of the bracket wall to enable secure fixing.
- C.14 Where there are shared surfaces, the designer must design out the risk presented by columns. If this cannot be achieved, passive safe columns along with electrical disconnect systems of an appropriate type shall be used. The designer must consult with Wexford County Council and approval granted before the system is specified.

Appendix D Supply Cabinet Specification

- D.1 Customer supply pillars shall be installed in land that is open to the public and never on private property.

ESB customer service pillars and midi pillars shall be installed a minimum of two metres apart as shown in *figure 5*. If this is not physically possible and only with the explicit permission of ESB Networks and the Roads Department of Wexford County Council these may be installed closer together and equi-potentially bonded in accordance to *ET101* (Electro-Technical Council of Ireland, 2016).

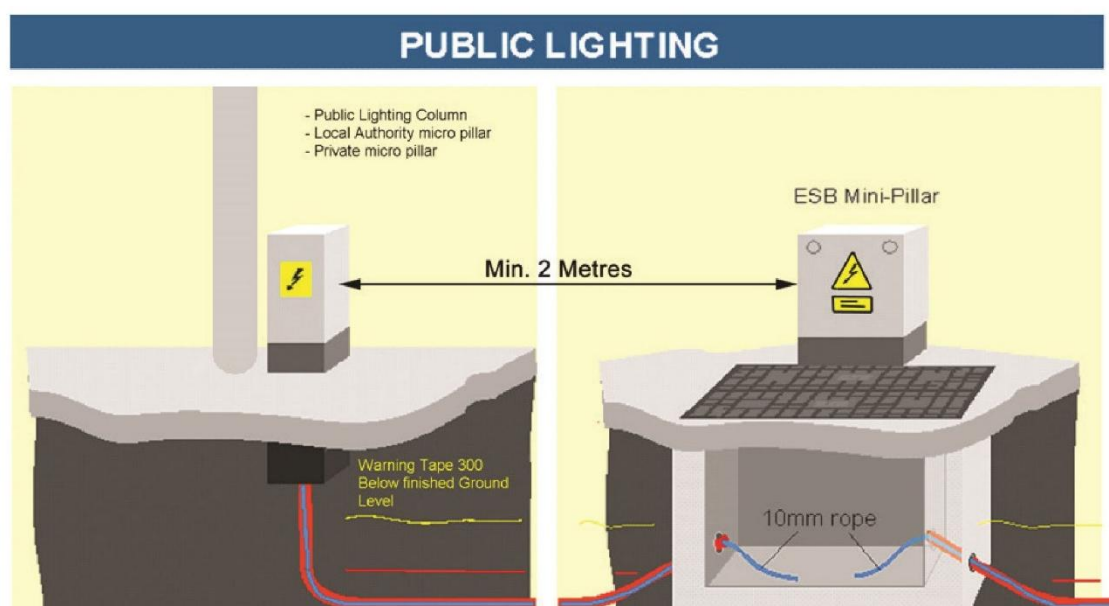

Figure 5: Pillar spacing

- D.2 Earthing for the customer service pillar should be in accordance with the *ESB National Code of Practice for Customer Interface 4th edition 2008*.
- D.3 The midi pillar (customer unmetered supply pillar) shall have typical dimensions of 150mm x 250mm x 600mm. Extension plates, or root assembly, typically 320mm deep shall be fitted at the bottom to enable firm cementing into the ground. Photographic evidence of correct installation shall be provided for each midi pillar and be available if requested by Wexford County Council.
- The extension plate, including the planted portion below ground and 50mm of the above ground shall be protected by a bitumous coating.
- D.4 The midi pillar shall be fitted with a single flat plate door nominally 220mm wide x 510mm high, with a triangular, captive head locking bolt.
- D.5 The midi pillar shall be vented. The venting shall be such that it protects against direct ingress of rain.
- D.6 The midi pillar shall be protected against corrosion by hot dip galvanising in accordance with *BS EN 1461* (International Organisation for Standardisation, 2015) and shall be properly vented.



A baseboard, approximately 20mm thick and treated with intumescent varnish shall be mounted in each pillar.

- D.7 All supply pillars shall have a high voltage symbol attached to the front panel.
- D.8 The main over current protective device shall be provided by a 32 amp rated high rupturing capacity type cut-out with a minimum rupturing capacity (short circuit level) of no less than 16KA to *BS HD 60269-2:2013, BS 88-2:2013* (British Standards Institute, 2013).

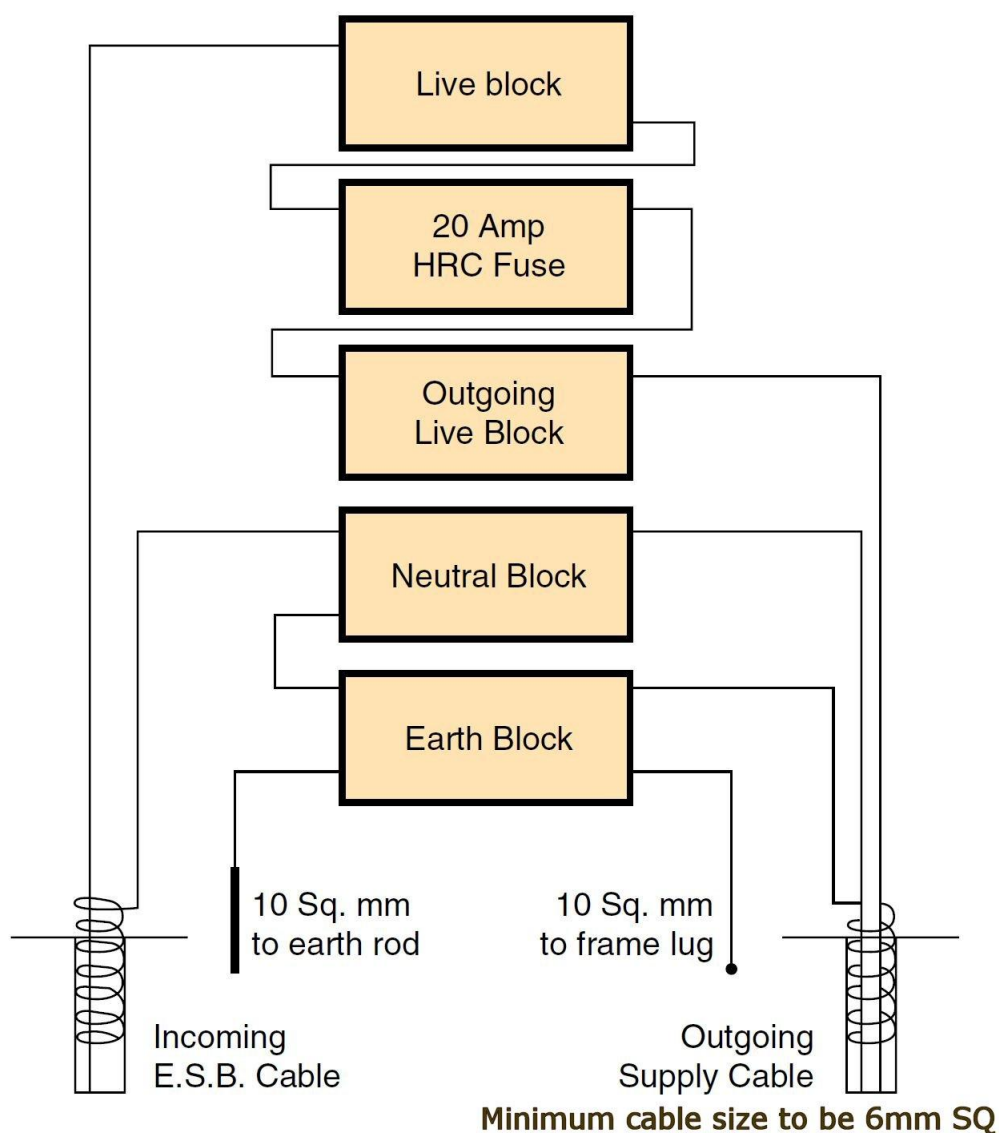

Figure 6: Midi pillar electrical schematic.

- D.9 Each outgoing circuit shall be individually fused by means of a 20A HRC cut-out type fuse.



- D.10 The live contacts of all fuse bases should be shrouded so accidental contact with live metal cannot be made when the fuse carrier is withdrawn. Terminals shall have a serrated bore to ensure good contact with all types of conductors. The use of M.C.B's shall not be accepted in public lighting columns or pillars.
- D.11 Each midi pillar must be earthed using an earth rod and the supply neutralised. The earth rod shall be either a bare copper or hot dipped galvanised iron pipe or rod of at least 16mm diameter. It shall be driven vertically into the soil for a length of not less than 1.2m.
- If ground conditions do not allow driving an earth rod, then a horizontal earth electrode can be used. It shall consist of 4.5m of bare copper or galvanised iron rod of 16mm diameter, or at least 4.5m of bare copper or galvanised steel wire of at least 25mm² cross sectional area buried in the soil at least 500mm deep.
- In certain ground conditions, *ESB Networks* may require additional earth procedures. Developers should check with *ESB Networks* to confirm their requirements.
- D.12 Evidence of the correct installation of the earth rod may be requested by Wexford County Council. The developer and/or the contractor should keep photographic, referenced records of the earth rod installation.
- D.13 A main earth terminal shall be mounted on the midi pillar baseboard, to which the following will be connected:
- D13.1 6mm² PVC cable from the earth terminal on the pillar. A crimped lug shall be used for the connection to the pillar.
 - D13.2 10mm² PVC cable from the earth electrode.
 - D13.3 6mm² PVC cable from the neutral link.
- D.14 The earthing lead to the earthing electrode shall exit the pillar via the service cable entry opening. The earth electrode connection shall be:
- D14.1 Enclosed in a galvanized steel box of 100mm³ approximately, with an inspection cover.
 - D14.2 Protected against corrosion by a suitable weatherproof tape.
 - D14.3 All to be buried underground after inspection to avoid damage by vandals.

Appendix E Column Installation

- E.1 All columns shall be installed and oriented so that the access door faces away from oncoming traffic as shown in *figure 7*.

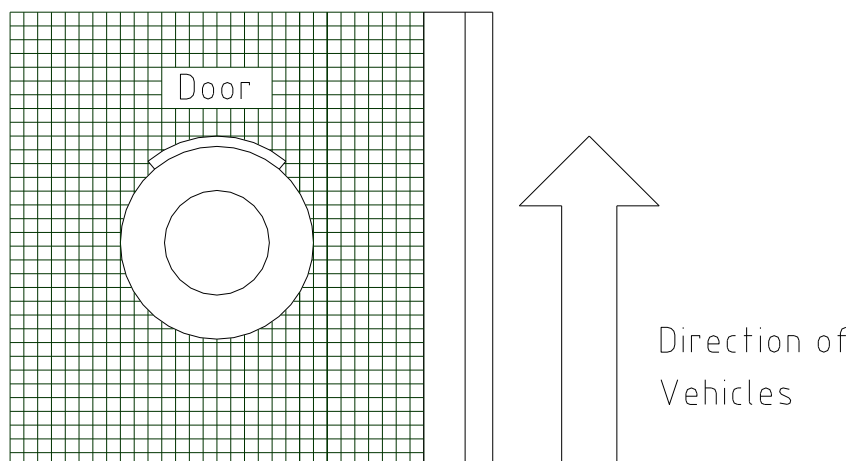

Figure 7: Door positioning.

- Columns must be erected securely and vertically in the exact positions indicated in the design drawings. Columns found to be in positions other than design locations unless previously agreed with Wexford County Council must be relocated to the design positions.
- E.2 Where columns are to be situated in the vicinity of overhead high tension cables, approval must be sought from the *ESBI Design Office* as to the exclusion zone with regards to the intended column height. Proof of this approval will be sought by Wexford County Council prior to taking in charge.
- E.3 Columns are to be installed in line with the recommended minimum clearances from the edge of the carriageway to the face of the lighting columns in *4.3.3.3 Table 2 of BS5489; 2013* (British Standards Institute, 2012).
- E.4 Columns shall be erected in line with the recommendations of *EN40-1* (British Standards Institute, 2013) regarding planting depths of columns. The contractor shall confirm with the column manufacturer/supplier the recommended depth for the root of the proposed columns.
- E.5 Columns shall be erected by planting their root portions in excavation of suitable size and secured. The excavated hole shall be pumped free of water prior to any filling with concrete.
- E.6 Where sleeves are used, they must have an outside diameter of 400mm minimum for 6m columns. This size may increase with increasing column base widths. Sleeves shall be installed such that the top of the sleeve finishes below the cable entry slot. Sleeves must be of a ridged construction.
- E.7 Where the rooting depths to *EN40-1* (British Standards Institute, 2013) are unachievable due to existing services or ground conditions, flange mounted columns may be used only with the prior written approval of Wexford County Council.



Where flanges are approved for use they must comply with EN40-1 (British Standards Institute, 2013).

A full set of design calculations for the structural base for the mounting of the flange, shall be undertaken by a competent person and must be submitted for Wexford County Council records.

E.8 All columns shall be set such that the centre of the column door is 1.5m above the finished ground level as shown in *figure 8*.

E.9 Close electrical protection of the column shall be provided by a 25A rated cut-out loaded with a 6A fuse incorporating a *cam lever* single pole disconnection. The cut-out will use a separate neutral and earth.

The cut-out must provide ingress protection to *IP 21* as defined by *EN 60529* (British Standards Institute , 2013).

Residual circuit devices or miniature circuit breakers shall not be used.

E.10 The column shall be earthed from the incoming cable via a 6mm² PVC cable which will be connected to the column by a crimped lug.

E.11 All columns shall have a switch fitted for testing purposes that bypasses the luminaire PECU. The switch shall be mounted securely on the column baseboard. The switch shall be 5 Amp rated and be protected to *IP42* (British Standards Institute , 2013).

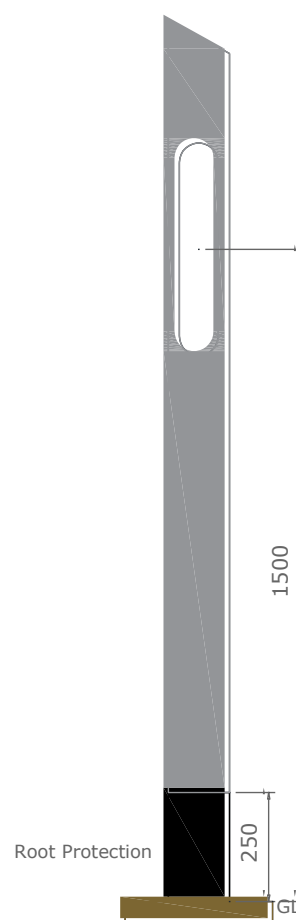

Figure 8: Column door height.

E.12 All components required for connection shall be firmly fixed to the column back board in a tidy and professional manner.

All conductors shall be stripped to the appropriate length to allow for connection. No exposed conductors shall be allowed.

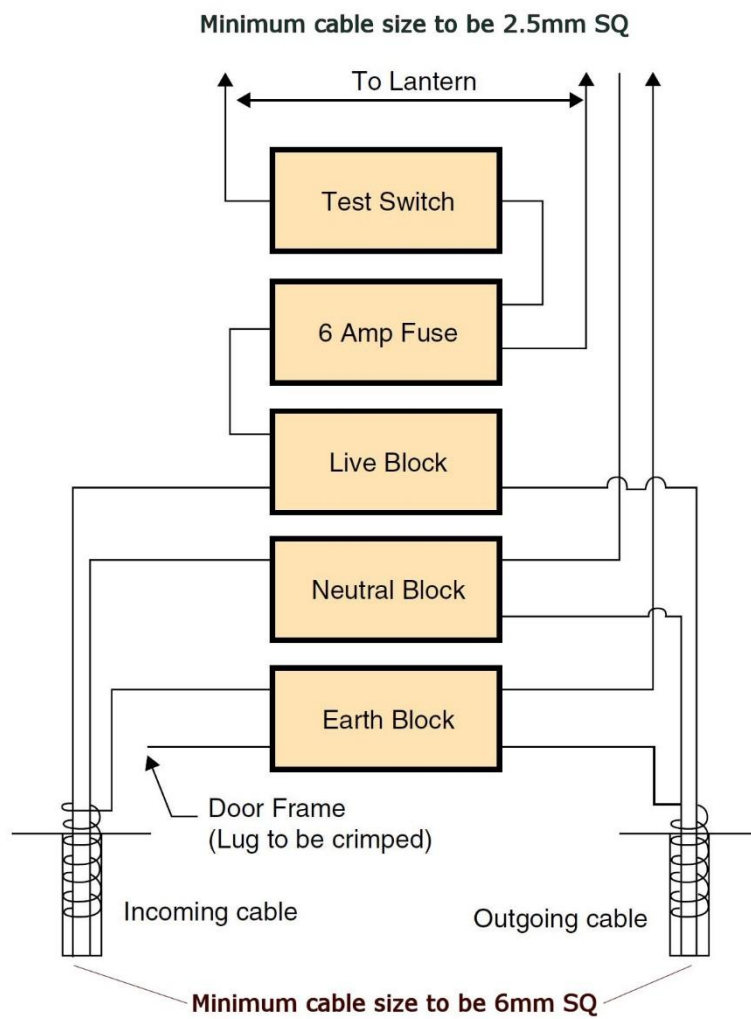

Figure 9: Column Electrical Schematic



Appendix F Electrical Design

F.1 The electrical services design for the scheme shall be undertaken to comply with *ETCI National Rules*. In particular the requirements set out in section 714 of *ET 101: 2008* (Electro-Technical Council of Ireland, 2016).

F.2 A detailed cable design shall be undertaken to match the calculated electrical load which would typically allow up to nine luminaires to be supplied per phase.

The provision of earth loop/fault level calculations and circuit disconnection (fuse rupture times) shall be undertaken by the electrical contractor.

Public lighting schemes requiring cable lengths in excess of 200 meters require careful design to meet the earth loop impedance requirements of *ET 101: 2008* (Electro-Technical Council of Ireland, 2016).

F.3 It is the duty of the installation contractor to ensure that disconnection/fuse rupture times shall be in compliance with those set out in *ET 101: 2008* (Electro-Technical Council of Ireland, 2016).

F.4 The contractor shall be responsible for the planned installation meeting the requirements of the *National Rules for Electrical Installations*. In particular, that the maximum volt drop is not exceeded, that fuses are sized to discriminate correctly and to blow within the appropriate time.

F.5 Miniature Circuit Breakers (MCB's) shall not be used in columns or pillars.

F.6 The main supply point switch fuse shall be a *BS 88 HRC* (British Standards Institute, 2013) fuse rated appropriately to the number of downstream circuits.

F.7 The fuses and circuit breakers shall have a minimum rupture capacity of *16kA*. All outgoing circuits shall be individually fused by means of a *20A HRC* cut-out type fuse.

F.8 Space shall be allocated for the ESB supplied cut-out and isolator as per the *ESBN National Code of Practice for Customer Interface* (ESBN, 2008).

F.9 Close protection of street lighting lanterns to be provided by a *25A* rated cut-out loaded with a *6A* fuse incorporating a cam lever double pole disconnection rated to *IEC 60947*.

The cut-out shall comply with a minimum degree of protection of *IP21* internally and *IP42* (British Standards Institute, 2013) externally and be moulded in a material which conforms to *BS 7654* (British Standards Institute, 2010), e.g. *MCO40DN* by *Lucy Oxford* or equivalent.

All terminals shall be formed from solid brass and be electroplated for temperature rise stability. Terminals shall have a serrated bore to ensure good contact with all types of conductors.

F.10 Switches for testing purposes shall be installed, either horizontally or vertically, in each public lighting column. These switches shall be so wired as to override the photoelectric cell during daylight hours.



The switches shall be 5A rated and must clearly indicate the "ON/OFF" position.

Switches must have a minimum rating of *IP42* (British Standards Institute , 2013).

Switches shall be securely mounted in an accessible position on the baseboard.

- F.11 Connector (Link) blocks shall be used for the termination of all conductors of underground cables in columns. The Connector blocks shall conform to *BS 7657:2010* (British Standards Institute, 2010) and rated *100Amp* for use on live and neutral connections. Each block shall incorporate five serrated cable bores (terminals) each capable of accepting cable sizes up to 35mm². The metal terminal block shall remain captured within its moulding when the cover is removed.

Connector blocks shall be solidly mounted on the column baseboards. Conductors shall not share the same terminal where spare ways are available in a connector block.



Appendix G LED Luminaire Specification

G.1 The luminaire shall be designed specifically to be used with LED light sources. It shall comply with all relevant EN standards and EC directives required by the CE *Community Marketing Directive*.

G.2 Products must be tested in laboratories independently accredited to *EN 60598* and *ISO/IEC 17025*.

Product quality and standard measurements will be based on *IEC/PAS 62717* and *IEC/PAS 62722*.

Products must be designed to *EN 60598* (European Committee for Electrotechnical Standardisation , 2009) by organisations independently accredited to that standard.

G.3 A *TM21* report must be provided as part of the design submission package.

An *LM80* report must be supplied as part of the design submission package.

G.4 The luminaire shall be supplied with surge protection of no less than 10kVa and shall be the first component in the luminaire's internal circuitry.

G.5 The light source shall be modular and replaceable on site. The module should be fixed in such a way as to maximise heat transfer from the LED chip and its respective board.

G.6 The LED shall be a natural white. Correlated Colour Index between 4,000 and 4,400 Kelvin.

G.7 The optic assembly will be protected to *IP66* as defined by *EN 60529* (British Standards Institute , 2013)

G.8 The lumen depreciation factor shall not exceed the following values at 100 000 hours at 25°C ambient:

When driven at 200mA, LDF \leq 10%

When driven at 350mA, LDF \leq 10%

When driven at 500mA, LDF \leq 10%

When driven at 700mA, LDF \leq 20%

When driven at 1 000mA, LDF \leq 25%

Luminaires that do not meet this requirement may be considered on an individual basis.

G.9 The driver shall be housed in a dedicated, separate chamber within the lantern. The enclosure will be protected to a minimum of *IP65* as defined by *EN 60529* (British Standards Institute , 2013) The *IP* rating must be capable of being maintained throughout the design life of the lantern.

G.10 The driver shall be *DALI* registered and capable of communication and interaction with a *CMS* communication module should it be required in the future.



The manufacturer shall ensure that the driver is compatible with the LED array being used, and that the driver complies with all appropriate regulations, standards, quality criteria and directives.

- G.11 Drivers shall utilise *Constant Lumen Output* as standard. Energy consumption and connected load shall be based on the average load over the products design life.
- G.12 Drivers shall have over temperature protection and provide power factor correction of no less than 0.9.
- G.13 The luminaire shall be constructed from die cast aluminium and powder coated in grey. All coloured components of the luminaire shall be of the same colour code (*RAL*) and have the same visual appearance when viewed together.

Other colours will be considered for decorative lighting applications.

- G.14 The luminaire will be constructed in a robust manner and be suitable to use in the intended application and location. The lantern shall have a minimum impact resistance of *IK08* (British Standards Institute, 2002).
- G.15 A signed declaration of conformity, along with certificates for ENC compliance and EMC Directive compliance shall be provided. The equipment will be fully compliant with RoHS requirements.
- G.16 The weight and projected side area should be stated for the luminaire with all equipment and angle of installation considered in order to calculate column load.
- G.17 Covers or openings on the luminaire required to be opened during the installation or maintenance of the light point must be captive when open.

All screws or fixtures required to be opened during installation or maintenance of the product must be protected against corrosion and seizure for the design life of the luminaire.

- G.18 LED failure fraction shall not be greater than 5% of the LEDs installed in the lantern over the design life of the lantern.
- G.19 The luminaire shall provide thermal protection for all its components to ensure the luminaire and its components operate within the stated temperature parameters through the design life of the lantern.
- G.20 Ambient temperature related to lantern performance and tests will be in the range of -35°C to +55°C. Lumen depreciation factor will be stated at 25°C.
- G.21 Electrical connection terminals shall be indelibly marked to indicate all wiring connections and use shrouded screws. Control equipment shall bear a clear circuit diagram in order to indicate all component connections in a concise manner.

An additional terminal will be required to enable overriding of the PECU by means of a 'line to test'.

- G.22 Operating voltages shall be clearly marked within the enclosure.



Electrical terminals shall be capable of terminating three core 2.5mm² flexible cable.

Any link cables, connector blocks and plug & socket arrangements must be of a suitable IP rating for their location and application and comply with all standards or directives.

- G.23 The complete luminaire including all component parts shall be guaranteed by the manufacturer for a minimum of ten years. Full written details of the warranty must be provided with the design submission.

A method statement defining how the warranty claims process should be accessed by Wexford County Council, or its agents, written by the manufacturer on the manufacturer's headed paper and signed by an identified director, must be provided with the design submission.

- G.24 Photometric performance, including lumen output used in designs shall be at an ambient temperature of 25⁰C. An *LM79* report shall be available if requested by Wexford County Council.

- G.25 Decorative luminaires will be considered individually, but they shall generally comply with the same requirements as a functional luminaire.

- G.26 Circuit Wattage (connected load) averaged for constant lumen output shall be stated for each luminaire variation proposed.

Drive current and power factor shall be stated for each luminaire variation proposed.

- G.27 The luminaire will be individually switched via a 7 pin NEMA socket, with all communication and power connections made at the time of assembly by the manufacturer.

A three pin PECU shall be used to switch the luminaire. The switch value shall be 35/18 lux.

Decorative luminaires shall utilise a miniature PECU with a 35/18 lux switching value. While the driver shall be enabled for dimming and communication via the *DALI* protocol, the communication cable shall not be connected.

- G.28 All luminaires shall have an indelible manufacturing data label affixed inside the driver compartment, clearly visible without the need to remove components. The label shall show the following information:

- Manufacturer name.
- Model number/code.
- Date of manufacture.
- Batch number, if relevant.

- G.29 The manufacturer shall provide the following information in accordance with the Lighting Industry Liaison Group's *A Guide to the Specification of LED Lighting Products*:



- Rated input power, identifying the amount of energy consumed by the lantern, including its power supply in Watts.
- Rated luminous flux in lumens in absolute photometric values. Absolute photometry results in a LOR=1
- Lantern efficacy in lumens per Watt.
- Luminous intensity distribution.
- Correlated colour temperature in Kelvin.
- Rated colour rendering index (CRI).
- Rated chromaticity co-ordinate values. Initial and maintained.
- Maintained luminous flux.
- Rated life in hours of the LED module and the associated rated lumen maintenance.
- Failure fracture corresponding to the rated life of the LED module within the lantern.
- Ambient temperature for the lantern.



Appendix H Taking in Charge

- H.1 It is the developer's responsibility to ensure that the lighting infrastructure installed is safe and fit for purpose.
- H.2 Wexford County Council will not take in charge any lighting infrastructure that does not meet the minimum standards and specifications laid down in this document, national codes of practise, international standards or statutory requirements.
- H.3 A full inspection of the public lighting infrastructure may be undertaken by a representative or agent of Wexford County Council, the cost of which will be borne by the developer.
- Should any deficiencies be found, they must be put right at the developer's cost before the lighting will be taken in charge.
- H.4 Wexford County Council shall not be liable for any maintenance or energy costs incurred prior to taking public lighting infrastructure in charge.
- H.5 Lighting equipment shall not be operated prior to inspection and approved permanent connection. It must not be operated as site lighting.
- H.6 Temporary connections shall not be undertaken.
- H.7 The developer or the designer/contractor should compile the following information essential for the Council's inspectors to complete their task and submit it, prior to inspection:

Copy of written approval of original design submission and written approval of any changes.

'As constructed' geo referenced CAD drawing in soft format showing the following information:

- Street Names;
- House numbers;
- Individually numbered column locations. The icon scale should be such that set back can be accurately assessed;
- Ducting locations;
- Cable access chambers;
- Individually numbered micro pillar locations;
- ESB cabinet locations;
- Individually numbered single line circuit diagrams;
- Private areas not to be taken in charge shall be hatched and identified.



Addendum 1 Designer Checklist

To ensure that your public lighting design application meets all requirements, please complete the following check list and attach all required documentation. Approval will not be granted if documents are missing or incomplete.

No lighting infrastructure installation may commence until written approval has been received.

Project name: _____
 Project location: _____
 Developer: _____
 Developer contact Details: _____
 Planning register number: _____
 Lighting designer: _____
 Designer contact details: _____
 Lighting class selected: _____

Approval for your lighting design cannot be processed or approved without the following documentation. Please confirm it has been completed and attached with your application:

- Lighting Reality® calculation in soft format
- Lighting Reality® Report in PDF format
- CAD drawing in soft format

Showing:

- The site boundary
- Private areas hatched and identified
- Landscaping features such as trees.
- Individually numbered column locations
- Ducting run locations
- Cable access chambers
- Individually numbered micro pillar locations
- ESB cabinet locations
- Individually numbered single line circuit diagrams
- All other services

- Technical specifications for the proposed equipment including TM 21 and LM80 report
- Written details of warranties and access to warranty procedure
- Voltage drop calculation for each circuit
- Energy calculations reflecting the designed dimming profile
- Designers risk assessment report

Sign _____

Print _____

Date _____



Addendum 2 Column Details

Root Protection

250

1500

GL

Root Protection

250

300

150

75

1000

200

200

50

300

Concrete

Root Protection

Concrete Cap

Compacted Sand

Reinforced Soil

Duct

Note that these dimensions will vary due to soil types and column styles

The detail is for mounting heights up to 6m with a single standard luminaire.

Please note that the dimensions and details shown in this drawing are for guidance only. They are not intended to be used as a design, loading, test conditions and other factors. Column foundation specifications should always be approved by a competent engineer.

| | |
|---|----------------------|
| Column Root Details (up to 6m mounting height) | |
| Public Lighting Specifications | |
| Project Name | Warracknup Council |
| Project No. | 14/02/17 |
| Revision | 0 |
| Drawn by | 0 |
| Checked by | 0 |
| Do not scale from drawing | All dimensions in mm |
| Redmond Analytical Management Services Ltd. | |
| 033 9333396 http://redmondms.com.au | |

REDMOND
ANALYTICAL MANAGEMENT SERVICES
LIGHTING | ENERGY | INFRASTRUCTURE

